

### GENERAL DESCRIPTION

The SGM42500 device is a brushed DC motor driver. This device integrates four N-MOSFETs, which can supply up to 3.6A peak current at 40V voltage.

The SGM42500 supports IN1/IN2 PWM interface. The PWM signal can be implemented on the input interface to adjust motor speed. Customer can adjust PWM current limit or torque in real-time by VREF pin with a controller's DAC output or PWM signal after RC filter.

A number of protection features are provided in the device including over-current, short-circuit, under-voltage lockout and thermal shutdown. When the fault condition is removed, the device automatically resumes normal operation.

The SGM42500 is available in a Green SOIC-8 (Exposed Pad) package.

### FEATURES

- H-Bridge Motor Driver
- Operating Voltage Range: 7V to 40V
- Low On-Resistance: 0.41Ω (HS + LS) at +25°C
- 3.6A Peak Output Current
- Interface: IN1/IN2
- Adjustable PWM Current Limit in Real-Time
- Low Power Standby Mode
- Integrated Protection Features
  - ◆ Over-Current Protection (OCP)
  - ◆ Under-Voltage Lockout (UVLO)
  - ◆ Thermal Shutdown (TSD)
  - ◆ Auto-Retry
- Available in a Green SOIC-8 (Exposed Pad) Package

### APPLICATIONS

- Printers
- Vacuum Cleaners Robotics
- Industrial Pumps and Valves

### TYPICAL APPLICATION

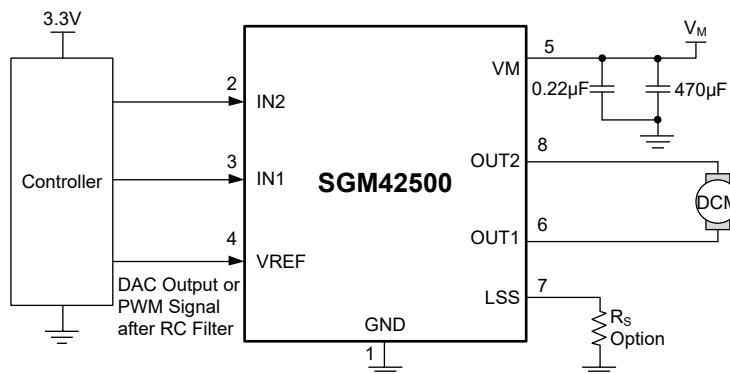

Figure 1. Typical Application Circuit

**PACKAGE/ORDERING INFORMATION**

MODEL	PACKAGE DESCRIPTION	SPECIFIED TEMPERATURE RANGE	ORDERING NUMBER	PACKAGE MARKING	PACKING OPTION
SGM42500	SOIC-8 (Exposed Pad)	-40°C to +125°C	SGM42500XPS8G/TR	SGM 42500XPS8 XXXXX	Tape and Reel, 4000

**MARKING INFORMATION**

NOTE: XXXXX = Date Code, Trace Code and Vendor Code.

**XXXXX**

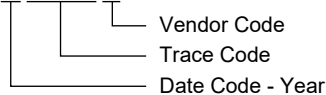

Green (RoHS & HSF): SG Micro Corp defines "Green" to mean Pb-Free (RoHS compatible) and free of halogen substances. If you have additional comments or questions, please contact your SGMICRO representative directly.

**ABSOLUTE MAXIMUM RATINGS**

Power Supply Voltage, $V_M$	45V
IN1, IN2	-0.3V to 6V
VREF	-0.3V to 5V
LSS	$\pm 0.5V$ (DC Condition)
	$\pm 2.5V$ (< 200ns)
Peak Output Current (Duty Cycle = 100%)	3.6A
Package Thermal Resistance	
SOIC-8 (Exposed Pad), $\theta_{JA}$	37°C/W
Junction Temperature	+150°C
Storage Temperature Range	-65°C to +150°C
Lead Temperature (Soldering, 10s)	+260°C
ESD Susceptibility	
HBM	2000V
CDM	1000V

**RECOMMENDED OPERATING CONDITIONS**

Power Supply Voltage, $V_M$	7V to 40V
Logic Input PWM Frequency (IN1, IN2), $f_{PWM}$	
	0kHz to 100kHz
Junction Temperature Range	-40°C to +150°C
Ambient Temperature Range	-40°C to +125°C

**OVERSTRESS CAUTION**

Stresses beyond those listed in Absolute Maximum Ratings may cause permanent damage to the device. Exposure to absolute maximum rating conditions for extended periods may affect reliability. Functional operation of the device at any conditions beyond those indicated in the Recommended Operating Conditions section is not implied.

**ESD SENSITIVITY CAUTION**

This integrated circuit can be damaged if ESD protections are not considered carefully. SGMICRO recommends that all integrated circuits be handled with appropriate precautions. Failure to observe proper handling and installation procedures can cause damage. ESD damage can range from subtle performance degradation to complete device failure. Precision integrated circuits may be more susceptible to damage because even small parametric changes could cause the device not to meet the published specifications.

**DISCLAIMER**

SG Micro Corp reserves the right to make any change in circuit design, or specifications without prior notice.

## PIN CONFIGURATION

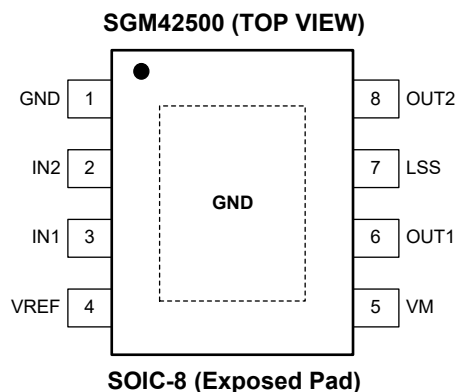

## PIN DESCRIPTION

PIN	NAME	TYPE	FUNCTION
1	GND	G	Ground.
2	IN2	I	Logic Input 2.
3	IN1	I	Logic Input 1.
4	VREF	I	Analog Input. Analog input to set current limit.
5	VM	P	Supply Voltage.
6	OUT1	O	H-Bridge Output 1. Output of H-bridge driving stage.
7	LSS	O	Power Return. Sense resistor connection (option) or connect to power pad ground directly.
8	OUT2	O	H-Bridge Output 2. Output of H-bridge driving stage.
Exposed Pad	GND	-	Exposed Pad. Exposed pad for enhanced thermal dissipation.

NOTE: I: input, O: output, G: ground, P: power for the circuit.

## ELECTRICAL CHARACTERISTICS

(T<sub>J</sub> = +25°C, unless otherwise noted.)

PARAMETER	SYMBOL	CONDITIONS	MIN	TYP	MAX	UNITS
<b>Power Supply (VM)</b>						
Power Supply Voltage	V <sub>M</sub>		7		40	V
Power Supply Current	I <sub>VM</sub>	V <sub>M</sub> = 12V		2	3	mA
Standby Mode Supply Current	I <sub>VMQ</sub>	V <sub>M</sub> = 12V		3	5	μA
<b>Logic Level Inputs</b>						
Input Logic Low Voltage	V <sub>IL</sub>	T <sub>J</sub> = -40°C to +125°C			0.5	V
Input Logic High Voltage	V <sub>IH</sub>	T <sub>J</sub> = -40°C to +125°C	1.5			V
Input Logic Hysteresis	V <sub>HYS</sub>			350		mV
Input Logic Low Current	I <sub>IL</sub>	V <sub>IN</sub> = 0V	-1		1	μA
Input Logic High Current	I <sub>IH</sub>	V <sub>IN</sub> = 3.3V		25	100	μA
Pull-Down Resistance	R <sub>PD</sub>	To GND		130		kΩ
Propagation Delay Time	t <sub>PD</sub>	INx to OUTx change		1.1		μs
<b>Motor Driver Outputs (OUT1 and OUT2)</b>						
High-side FET On-Resistance	R <sub>DSON</sub>	V <sub>M</sub> = 24V, I <sub>OUT</sub> = 0.5A		250	300	mΩ
Low-side FET On-Resistance		V <sub>M</sub> = 24V, I <sub>OUT</sub> = 0.5A		160	190	mΩ
Body Diode Forward Voltage <sup>(1)</sup>	V <sub>D</sub>	I <sub>OUT</sub> = 1A		0.8		V
<b>Timing</b>						
Turn-On Time <sup>(2)</sup>	t <sub>ON</sub>	V <sub>M</sub> > V <sub>UVLO</sub> with IN1 or IN2 high		130		μs
Crossover Delay	t <sub>COD</sub>			400		ns
VREF Input Voltage Range	V <sub>REF</sub>		0		4	V
VREF Voltage Gain	A <sub>V</sub>	V <sub>REF</sub> /V <sub>LSS</sub> , V <sub>REF</sub> = 2.5V	9.2	10	11.3	V/V
Constant Off-Time	t <sub>OFF</sub>			12.5		μs
Standby Timer	t <sub>ST</sub>	IN1 = IN2 = 0V		1	1.5	ms
<b>Protection Circuits</b>						
VM Under-Voltage Lockout	V <sub>UVLO</sub>	V <sub>M</sub> falls until UVLO triggers		6	6.6	V
		V <sub>M</sub> rises until operation recovers		6.2	6.8	
VM Under-Voltage Hysteresis	V <sub>HYS</sub>	Rising to falling threshold	100	200		mV
Over-Current Protection Trip Level	I <sub>OCP</sub>			4		A
Over-Current Deglitch Time	t <sub>OCP</sub>			2		μs
Over-Current Retry Time	t <sub>RETRY</sub>			10		ms
Thermal Shutdown Temperature	T <sub>SD</sub>			165		°C
Thermal Shutdown Temperature Hysteresis	T <sub>HYS</sub>			30		°C

## NOTES:

1. It is recommended that the maximum current of the body diode should be less than 1.5A.
2. t<sub>ON</sub> applies when the device initially powers up, and when it exits standby mode.

PWM CONTROL TIMING DIAGRAM

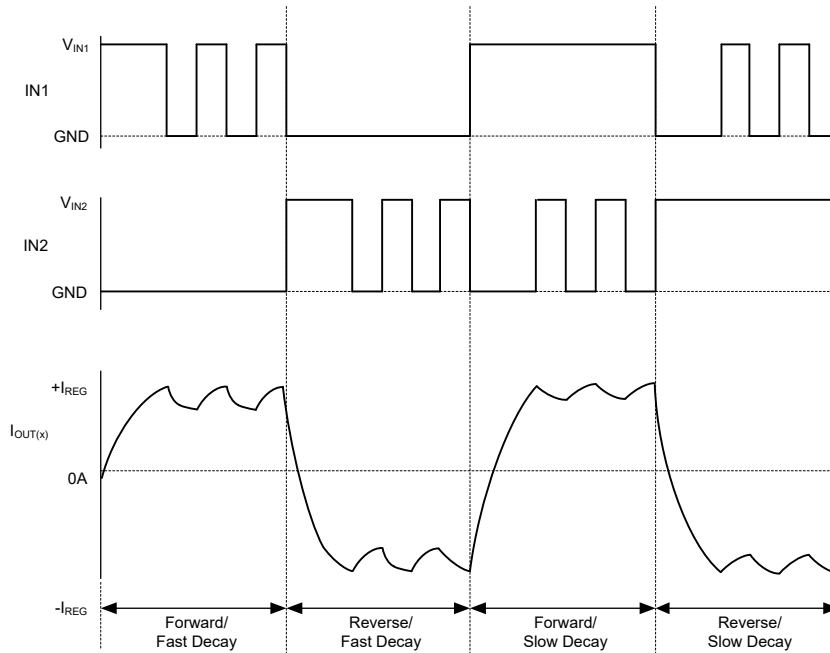

TRUTH TABLE

Table 1. SGM42500 PWM Control Truth Table

IN1	IN2	OUT1	OUT2	Function
0	1	L	H	Reverse
1	0	H	L	Forward
1	1	L	L	Brake (Slow Decay)
0	0	Z	Z	Coast, enter in the low power standby mode after 1ms. It will be a fast decay that discharges through the body diode.

NOTE: Z = high-impedance.

Table 2. SGM42500 PWM Decay Logic

IN1	IN2	Decay Logic
PWM	1	Slow Decay
PWM	0	Fast Decay
1	PWM	Slow Decay
0	PWM	Fast Decay

The inputs can also be used for PWM control, for example, the speed of a DC motor. The PWM signal can be applied to IN1 or IN2 pin.

If one input is set to high and the other input is set to PWM, the decay mode is slow decay. When IN1 is high and IN2 is PWM, the motor is running forward. When IN2 is high and IN1 is PWM, the motor is running reverse.

If one input is set to PWM and the other input is set to low, the decay mode is fast decay. When IN1 is PWM and IN2 is low, the motor is running forward. When IN2 is PWM and IN1 is low, motor is running reverse.

FUNCTIONAL BLOCK DIAGRAM

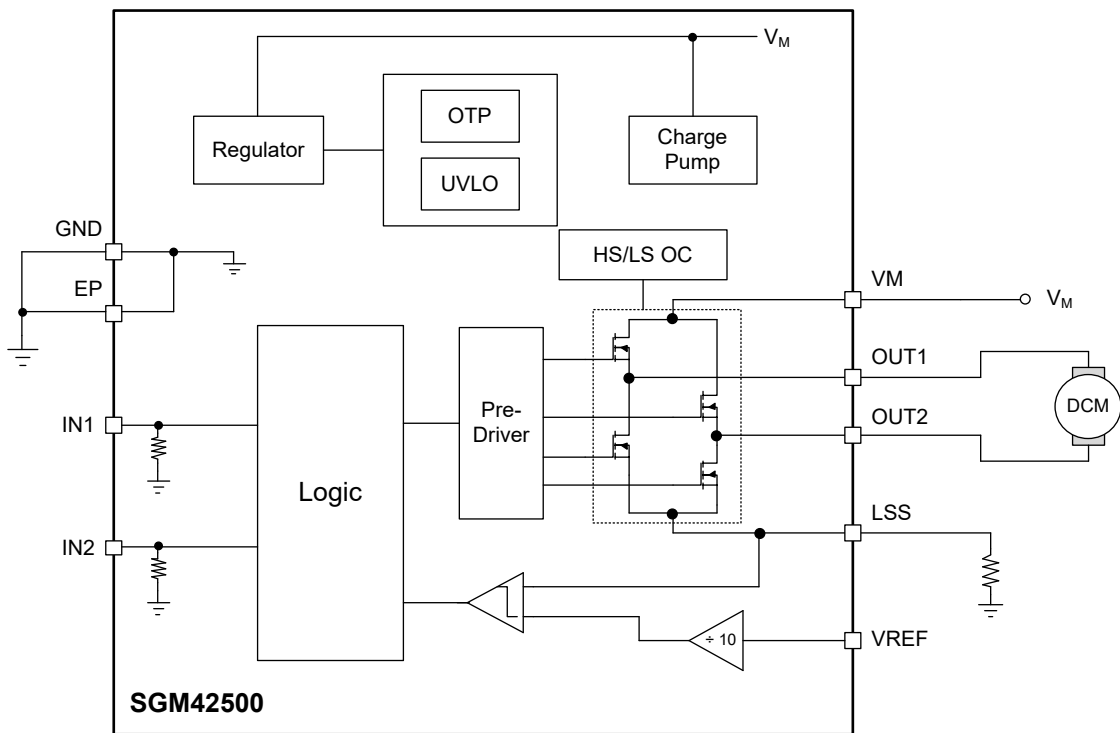
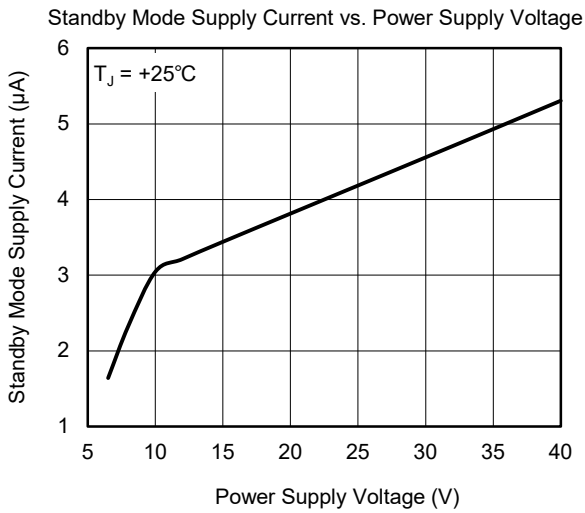
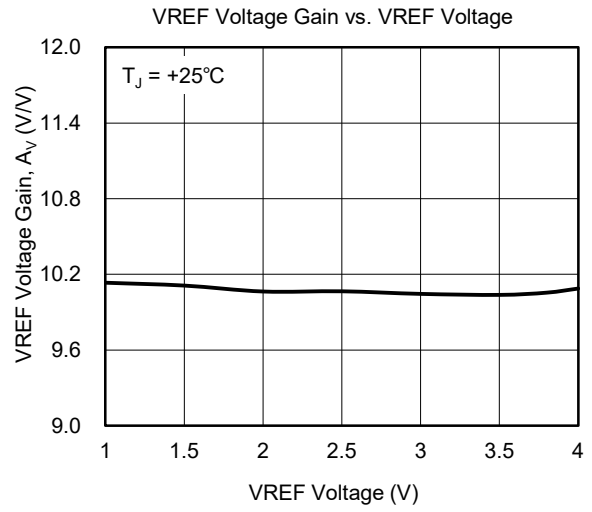
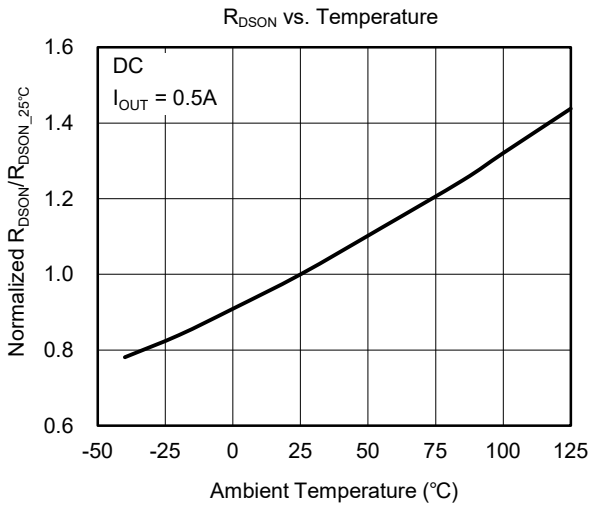

Figure 2. SGM42500 Functional Block Diagram

TYPICAL PERFORMANCE CHARACTERISTICS



## DETAILED DESCRIPTION

### Device Operation

The SGM42500 is typically used to drive a DC motor. An internal charge pump generates the necessary gate-drive voltage. The SGM42500 operates from 7V to 40V motor power supply, which can supply a 3.6A peak current. Full protection features include over-current protection, under-voltage lockout and over-temperature protection.

### Standby Mode

For SGM42500, if both input pins (IN1/IN2) are low for longer than 1ms, the device will go to standby mode. If entering the standby mode, the output MOSFET, charge pump, and regulator are turned off for saving power.

### Internal PWM Current Control

The current in the output is limited using fixed off-time control circuitry. If the motor current goes over the current limit setting, the two low-side MOSFETs are both turned on for  $t_{OFF}$  time, slow decay mode is used to adjust the current.

### $V_{REF}$

The current limit is decided by  $V_{REF}$  and  $R_S$  together, please refer to Equation 1:

$$I_{TRIPMAX} = \frac{V_{REF}}{10 \times R_S} \quad (1)$$

### Over-Current Protection (OCP)

Each MOSFET is protected by its own preset over-current limit. In case of an over-current (any direction), the whole bridge will be disabled (shutdown), and the device will retry after  $t_{RETRY}$ . An over-current will occur due to a short between a switching node and ground, VM supply line, or the other node of the bridge (a winding short).

### Under-Voltage Lockout (UVLO)

If the voltage on VM pin falls below its under-voltage lockout threshold, the device will be disabled. The device resumes operation when the power supply goes back above UVLO thresholds.

### Thermal Shutdown (TSD)

The driver is shutdown if a junction over-temperature occurs in the device. Once the temperature goes back to the safe level, the device resumes its operation.



**APPLICATION INFORMATION**

**Sense Pin (LSS)**

If PWM current control is used, it is recommended to place a low-value resistor between the LSS and GND pins for current sensing. In order to detect the output current, the ground trace IR drop should be minimized. Surface mounted and low inductance sense resistor is recommended. It is necessary to consider the package, since  $I^2 \times R$  heat is generated in the sense resistor. And during PCB layout, place the resistor near to the motor driver as close as possible.

Ensure that the maximum voltage of LSS ( $\pm 500\text{mV}$ ) is not exceeded at the maximum load, and select the appropriate resistance value. This rating may be exceeded for a short time during an over-current event.

**Ground and Layout Guidelines**

The power supply VM is suggested to be decoupled with a bulk capacitor in parallel with a lower value ceramic capacitor placed as close as practicable to the device.

The exposed pad on the bottom of the device provides a path for heat dissipation. The pad should be soldered directly to an exposed surface on the PCB board to achieve better thermal performance. Thermal vias are also helpful to dissipate the heat.

It is good to have a low impedance single-point ground, known as a star ground, which is located close to the SGM42500. The copper ground plane located under the device thermal pad is typically used as the star ground.

**REVISION HISTORY**

NOTE: Page numbers for previous revisions may differ from page numbers in the current version.

<b>JANUARY 2023 – REV.A to REV.A.1</b>		<b>Page</b>
Updated Electrical Characteristics section .....		4
<b>Changes from Original (OCTOBER 2022) to REV.A</b>		<b>Page</b>
Changed from product preview to production data .....		All

PACKAGE OUTLINE DIMENSIONS

SOIC-8 (Exposed Pad)

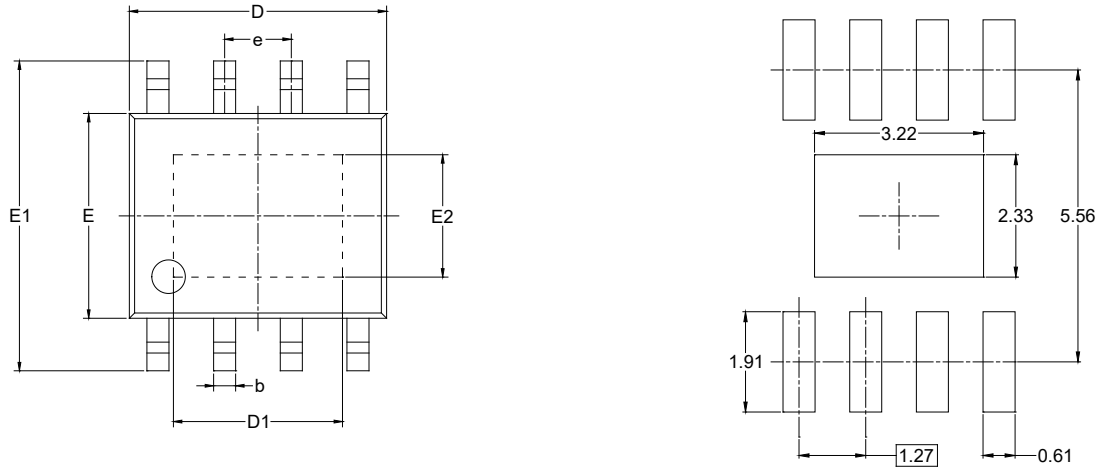

RECOMMENDED LAND PATTERN (Unit: mm)

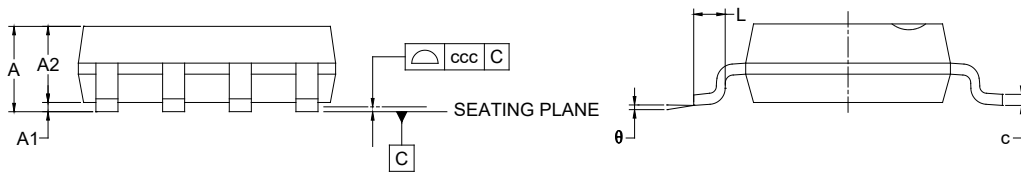

Symbol	Dimensions In Millimeters		
	MIN	MOD	MAX
A			1.700
A1	0.000	-	0.150
A2	1.250	-	1.650
b	0.330	-	0.510
c	0.170	-	0.250
D	4.700	-	5.100
D1	3.020	-	3.420
E	3.800	-	4.000
E1	5.800	-	6.200
E2	2.130	-	2.530
e	1.27 BSC		
L	0.400	-	1.270
θ	0°	-	8°
ccc	0.100		

NOTES:

1. This drawing is subject to change without notice.
2. The dimensions do not include mold flashes, protrusions or gate burrs.
3. Reference JEDEC MS-012.

# PACKAGE INFORMATION

## TAPE AND REEL INFORMATION

### REEL DIMENSIONS



### TAPE DIMENSIONS



NOTE: The picture is only for reference. Please make the object as the standard.

### KEY PARAMETER LIST OF TAPE AND REEL

Package Type	Reel Diameter	Reel Width W1 (mm)	A0 (mm)	B0 (mm)	K0 (mm)	P0 (mm)	P1 (mm)	P2 (mm)	W (mm)	Pin1 Quadrant
SOIC-8 (Exposed Pad)	13"	12.4	6.40	5.40	2.10	4.0	8.0	2.0	12.0	Q1

000001

# PACKAGE INFORMATION

## CARTON BOX DIMENSIONS



NOTE: The picture is only for reference. Please make the object as the standard.

## KEY PARAMETER LIST OF CARTON BOX

Reel Type	Length (mm)	Width (mm)	Height (mm)	Pizza/Carton
13"	386	280	370	5

DD0002